

# Technical data sheet



## Product features

<b>Model</b>	<b>SAP Code</b>	00002053
SPT 60 GLS	<b>A group of articles - web</b>	Stoves



- Device type: Combined unit
- Number and power / input of zones 1: 4x 4,5 kW
- Type of internal part of the appliance 1 (eg oven): Electric
- Type of internal part of the appliance 2 (eg oven): Hot air
- Protection of controls: IPX4
- Material: AISI 304 top plate, AISI 430 cladding
- Worktop Thickness [mm]: 0.80

<b>SAP Code</b>	00002053	<b>Type of gas</b>	Natural gas, propane butane
<b>Net Width [mm]</b>	658	<b>Number and power / input of zones 1</b>	4x 4,5 kW
<b>Net Depth [mm]</b>	609	<b>Type of internal part of the appliance 1 (eg oven)</b>	Electric
<b>Net Height [mm]</b>	900	<b>Type of internal part of the appliance 2 (eg oven)</b>	Hot air
<b>Net Weight [kg]</b>	65.00	<b>Width of internal part [mm]</b>	548
<b>Power electric [kW]</b>	3.130	<b>Depth of internal part [mm]</b>	360
<b>Loading</b>	230 V / 1N - 50 Hz	<b>Height of internal part [mm]</b>	338
<b>Power gas [kW]</b>	18.000		

# Technical data sheet



Technical drawing

<b>Model</b>	<b>SAP Code</b>	00002053
SPT 60 GLS	<b>A group of articles - web</b>	Stoves

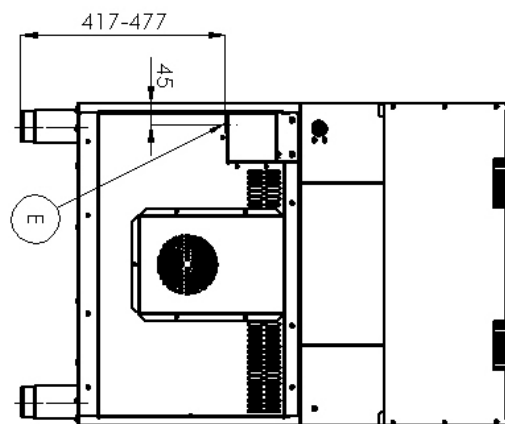
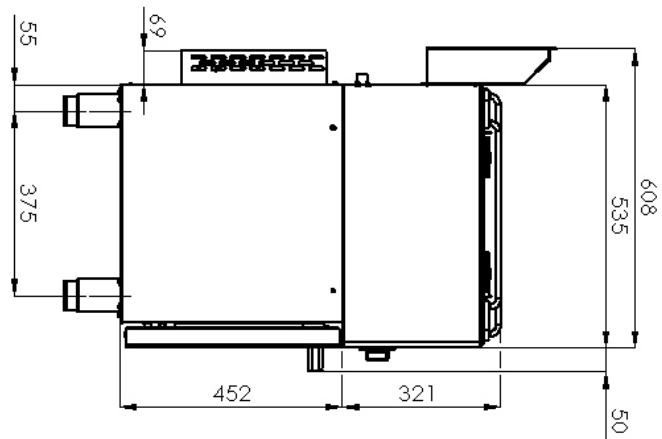
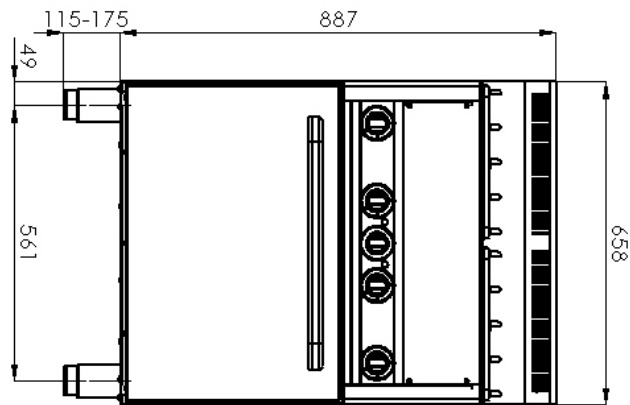

<b>Model</b>	<b>SAP Code</b>	00002053
SPT 60 GLS	<b>A group of articles - web</b>	Stoves

### 1 Centered high performance burners

- high performance and efficiency
- brass removable burners
- long life
- detachable
  - energy saving (perfect combustion)
  - time saving for food preparation
  - easy maintenance/cleaning

### 7 Removable basin under the burners

- removable top plate without tools
  - easier cleaning
  - dishwasher safe
  - easier servicing

### 2 Hygienic moldings of the top plate

- absence of sharp corners and edges (potential places where dirt could stick)
- smooth transitions
  - easy quick cleaning

### 3 Hot air oven

- hot air baking
- high capacity and variability
- all-stainless design
  - suitable for meat, fish, baked pasta, white meat, sweet pastries
  - long service life
  - easy to clean

### 4 Degree of protection of the control elements IPX4

- maintenance-free system
- resistance to splash water
- long life
  - savings on service interventions
  - greater job security for staff

### 5 All stainless steel design

- long life
- resistance of AISI 304 stainless steel material
- the material does not cut
  - savings on service interventions
  - easy cleaning and maintenance of equipment

### 6 Safety element - thermocouple

- safe service for staff
- there is no unnecessary gas leakage
- long life
  - savings on service interventions
  - easier and faster operation

# Technical data sheet



## Technical parameters

<b>Model</b>	<b>SAP Code</b>	00002053
SPT 60 GLS	<b>A group of articles - web</b>	Stoves

**1. SAP Code:**

00002053

**2. Article group:**

RF-Line 600

**3. Net Width [mm]:**

658

**4. Net Depth [mm]:**

609

**5. Net Height [mm]:**

900

**6. Net Weight [kg]:**

65.00

**7. Gross Width [mm]:**

705

**8. Gross depth [mm]:**

725

**9. Gross Height [mm]:**

1120

**10. Gross Weight [kg]:**

72.00

**11. Device type:**

Combined unit

**12. Construction type of device:**

With substructure

**13. Power electric [kW]:**

3.130

**14. Loading:**

230 V / 1N - 50 Hz

**15. Power gas [kW]:**

18.000

**16. Type of gas:**

Natural gas, propane butane

**17. Protection of controls:**

IPX4

**18. Material:**

AISI 304 top plate, AISI 430 cladding

**19. Indicators:**

running and heating the oven

**20. Worktop material:**

AISI 304

**21. Worktop Thickness [mm]:**

0.80

**22. Number and power / input of zones 1:**

4x 4,5 kW

**23. Number of power control stages:**

6

**24. Safety thermostat up to x ° C:**

360

**25. Adjustable feet:**

Yes

**26. Number of burners/hot plates:**

4

**27. Type of gas cooking zones:**

Mosazné hořáky

**28. Oven Type:**

electric hot air

**29. Type of internal part of the appliance 1 (eg oven):**

Electric

**30. Type of internal part of the appliance 2 (eg oven):**

Hot air

**31. Width of internal part [mm]:**

548

**32. Depth of internal part [mm]:**

360

# Technical data sheet



Technical parameters

<b>Model</b>	<b>SAP Code</b>	00002053
SPT 60 GLS	<b>A group of articles - web</b>	Stoves

**33. Height of internal part [mm]:**

338

**35. Minimum temperature of the inner chamber [°C]:**

50

**34. Maximum temperature of the inner chamber [°C]:**

300

**36. Number of internal parts:**

4